

ISO1 - Single sub-base, side connections

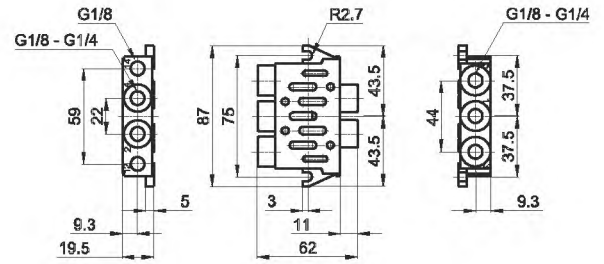

Notes	Connection	Material	Weight Kg	Part no.
in line connections	G1/8	zamak	0,250	BF-1060
in line connections	G1/4	zamak	0,230	BF-1061



1 = Supply port
2 - 4 = Use
3 - 5 = Exhaust
12 - 14 = Pilots

ISO2 - Single sub-base, side connections



Notes	Connection	Material	Weight Kg	Part no.
in line connections	G1/4	zamak	0,640	BF-1150
in line connections	G3/8	zamak	0,650	BF-1151

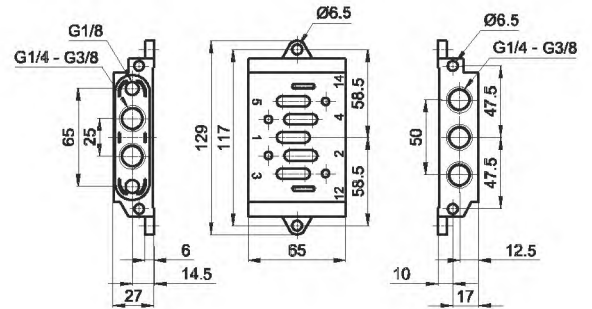

1 = Supply port
2 - 4 = Use
3 - 5 = Exhaust
12 - 14 = Pilots

ISO3 - Single sub-base, side connections



Notes	Connection	Material	Weight Kg	Part no.
in line connections	G1/2	aluminium	0,740	BF-3060
in line connections	G3/4	aluminium	0,740	BF-3061

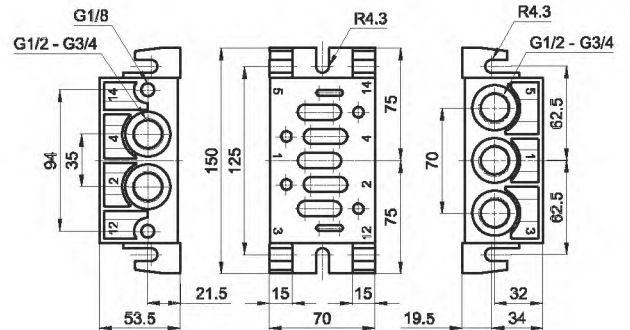

1 = Supply port
2 - 4 = Use
3 - 5 = Exhaust
12 - 14 = Pilots

ISO4 - Single sub-base, side connections



Notes	Connection	Material	Weight Kg	Part no.
in line connections	G3/4	aluminium	1,280	BF-4060
dorsal and side connections	G1	aluminium	1,280	BF-4061

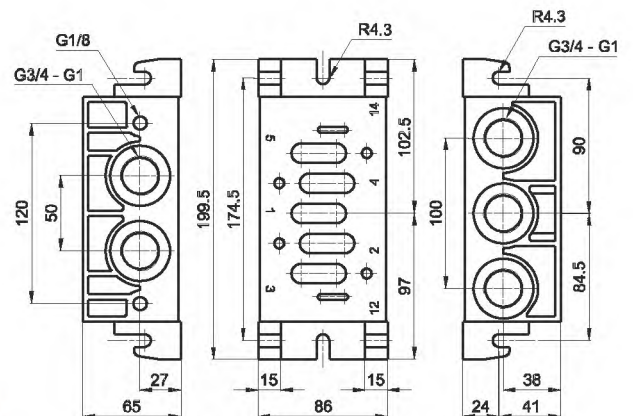

1 = Supply port
2 - 4 = Use
3 - 5 = Exhaust
12 - 14 = Pilots